

removed) a second crop of strychnine glycollate, 6.5 g.,¹ melting from 150–195° with $[\alpha]_D^{20} = -25.74^\circ$, was obtained.

The aqueous solution of 8.1 g. of gum (page 1650) dissolved 15.45 g. of strychnine. From the alcoholic solution of the crude salts, 3.6¹ g. of strychnine glycollate, melting from 150–195° with $[\alpha]_D^{20} = -22.1^\circ$, separated out.

On decomposition with barium hydroxide, the combined drops, 6.5 g. and 3.6 g., yielded 7.7 g. of strychnine and 1.9 g. of gum (+13.16°); the crop of 13.49 g. of salt gave 10.95 g. of strychnine and 2.3 g. of gum (+8.7°). By evaporating the aqueous solution of the combined gums on a boiling water bath for 13 hours, 1.7 g. of glycollic acid were expelled leaving 2.5 g. of gum (+22.6°).

From the two crops of secondary strychnine oxalate combined, 4.78 g., 3.9 g. of strychnine and 0.7 g. of oxalic acid crystals were obtained.

Summary.

Oxidation of Arabinose by Air.—The products obtained from 50 g. of substance were: 15.35 g. of formic acid, 3.7313 g. of calcium glycollate, 14.12 g. of *l*-erythronic γ -lactone, 0.68 g. of *d*-threonic phenylhydrazide, 0.33 g. of quinine *l*-glycerate and 0.44 g. of calcium *d*-glycerate.

Oxidation of *l*-Arabinose by Cupric Hydroxide.—The products obtained from 100 g. of substance were 2.92 g. of glycollic acid (volatilized), 1.38 g. of oxalic acid, 2.63 g. of *l*-arabonic γ -lactone.

Oxidation of *l*-Xylose by Air.—The products obtained from 50 g. of substance were 13.17 g. of formic acid, 18.09 g. of *l*-threonic phenylhydrazide, 0.06 g. of *d*-erythronic γ -lactone, 4.9422 g. of calcium glycollate, 0.37 g. of calcium *l*-glycerate.

Oxidation of *l*-Xylose by Cupric Hydroxide.—The products obtained from 100 g. of substance were 6.42 g. of *l*-xylonic γ -lactone, 1.1 g. of *d*-lyxononic γ -lactone, 1.7 g. of glycollic acid (volatilized), and 0.7 g. of oxalic acid.

CHICAGO, ILL.

[CONTRIBUTION FROM THE CHEMICAL LABORATORY OF THE UNIVERSITY OF MICHIGAN.]

TRIPHENYLMETHYL. XXVII. THE MOLECULAR WEIGHTS OF THE TRIARYLMETHYLS.

By M. GOMBERG AND C. S. SCHOEPFLE.

Received May 26, 1917.

It is now generally accepted that the "free radicals" of the triphenylmethane series owe their unique and distinctive character to the presence

¹ The gummy strychnine salts from the filtrates, on decomposition with barium hydroxide, yielded 19.35 g. of gum from which ether extracted 11.8 (+3.81°). From the insoluble portion ethyl acetate extracted 5.6 g. (+14.16°) leaving 2.25 g. of tarry gum. Brucine salts were prepared from 11.8 g. of gum; from alcoholic solution these yielded 22.77 g. of brucine salts melting from 198–207°.

of a trivalent carbon atom in the molecule. In many cases the molecular weight has been found to be double that calculated for the free radical. Nevertheless, even in these cases the presence of a compound with a single unsaturated carbon atom is still recognized, and the assumption is made that there exists, in virtue of partial dissociation, a mobile equilibrium:

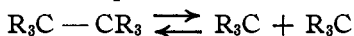

It is doubtful whether the matter is quite as simple as it is represented by the above equation. From a variety of experimental evidence¹ the conclusion seems inevitable that both the hexa-arylethanes and the triarylmethyls exist in two tautomeric modifications. Recently Lewis, in applying his very suggestive hypothesis of "odd molecules" in order to explain the character of the triarylmethyl-methyls, concurs in the opinion that "the recognition of the existence of the quinoid form is indispensable to an understanding of numerous reactions which characterize the hexa-arylethanes"² It is far more likely that triarylmethyls, at least when in solution, conform to the following scheme:³

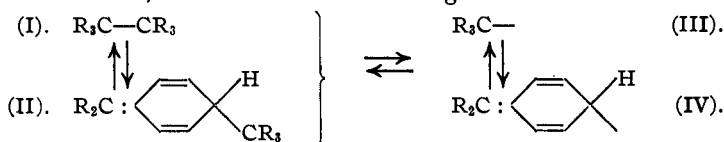

In other words, there is a tautomeric equilibrium between the benzenoid hexa-arylethane (I) and the quinol (II); also between the benzenoid triarylmethyl (III) wherein the central carbon atom is trivalent and its quinonoid modification (IV) wherein the *para*-carbon atom in the nucleus assumes the trivalent state. This viewpoint is not only in harmony with the peculiar chemical behavior of this class of compounds, but it also relieves us of the necessity of straining experimental data to an embarrassing point in order to account for certain characteristics of these same compounds. It permits us, for instance, to explain by the presence of the quinol tautomer (II) the existence of a colored modification of hexa-arylethanes in cases where molecular-weight determinations fail to indicate a measurable degree of dissociation. And even in those cases where a partial or complete dissociation of the hexa-arylethane is demonstrable, the fact that the solution is colored finds a more reasonable and more concordant explanation in the existence of the quinonoid tautomeric triarylmethyl (IV) than merely in that of the benzenoid (III) alone.⁴

Whether, however, the supplemental hypothesis of tautomerism is accepted or not, the fact remains that we are dealing here primarily with

¹ *Ber.*, 40, 1860 (1907); *Ann.*, 370, 190 (1909); 376, 208 (1910); *Ber.*, 42, 406 (1909).

² *Proc. Nat. Acad. Sci.*, 2, 588 (1916).

³ *Ber.*, 46, 228 (1913).

⁴ *THIS JOURNAL*, 36, 1167 (1914).

a phenomenon where a hydrocarbon dissociates spontaneously into two parts, which parts may also spontaneously reassociate with the production of the original substance. It seems reasonable to speak of the parts as monomolecular free radicals, and of the original hydrocarbon as the dimolecular triarylmethyl, in virtue of the readiness with which the latter goes over into the former. Such an appellation for the latter, it must be admitted, is not as strictly accurate as the name hexa-arylethane; it none the less has the advantage that it suggests a behavior of the compound which ordinarily would neither be expected nor suspected in the ethane derivatives.

What are the factors which influence the degree of dissociation in a given hexa-arylethane? What is the relation between the degree of the dissociation and the nature of the aryl group in the substituted ethane?

Factors Influencing Dissociation.—Obviously, the nature of the solvent, the temperature of the solution, and the concentration of the solute must be the chief factors as regards the extent of dissociation which may be reached by a given hexa-arylethane.

With regard to changes in the equilibrium between the dimolecular and the monomolecular modification due to the temperature, it has been found that the molecular weight of triphenylmethyl in naphthalene at 79–80° is approximately 414, while the average value found with other solvents such as benzene, nitrobenzene, etc., which freeze at temperatures around 0–5° is between 480 and 485.¹ A computation from these molecular-weight determinations indicates that triphenylmethyl exists in the monomolecular state to an extent of 17% in naphthalene at 80°, while to considerably less than 5%, if at all, in benzene at 6°. Schlenk and Mair² determined the molecular weight of triphenylmethyl in benzene by the ebullioscopic method, and found that at the temperature of the boiling point of benzene, also about 80°, the hydrocarbon is dissociated in the monomolecular phase to the extent of 23.3–29.9% with approximately a 2% concentration. However, these results do not check as well as could be desired, the variation amounting to 6.6% or about 25% of the total dissociation. Schmidlin³ calls attention to the fact that it is very difficult to obtain an absolutely pure sample of triphenylmethyl, and that samples prepared by slightly different methods often differ considerably in purity. Therefore he suggests the possibility that the variation between the molecular weights found by Schlenk with the ebullioscopic method and by Gomberg and Cone with the cryoscopic method may be due to differences in the degree of purity of the samples used. Accordingly Schmidlin⁴ constructed a special apparatus containing two thermometers, by means of

¹ Gomberg and Cone, *Ber.*, 37, 2037 (1904).

² *Ann.*, 394, 179 (1912).

³ Schmidlin, "Das Triphenylmethyl" (Stuttgart, 1914), p. 74.

⁴ *Ber.*, 45, 3180 (1912).

which he could determine the molecular weight in benzene first by the ebullioscopic method and then by the cryoscopic method. However the molecular weights of triphenylmethyl found by the two methods showed no appreciable difference in value, and therefore no change in dissociation between the temperatures of 6° and 80° was noticeable.

With regard to the influence of concentration upon the degree of dissociation of hexaphenylethane, an examination of the results obtained by various investigators fails to reveal a concordant influence of this factor. One might infer from the published molecular weights with some solvents that perhaps the dissociation increases, as it should, with the decrease of concentration, but the change is very slight. On the other hand, with *p*-bromotoluene as a solvent practically the same molecular weights are obtained with concentrations varying from 1.5 to 9% of the unsaturated hydrocarbon.¹

Piccard² has sought to ascertain the influence of the concentration factor upon dissociation by a different method. According to Beer's law, a solution when viewed through a colorimeter should show no change in color upon dilution, for the thickness of the solution in the cylinder increases proportionately as the concentration decreases. But Piccard found that a 5% ether solution of triphenylmethyl upon dilution in this manner shows an increase in color from a light yellow to a dark orange-red. He explained this by assuming that, as the concentration decreases, the colorless dimolecular phase is dissociated further and further into the colored monomolecular phase of triphenylmethyl, until in extremely dilute solutions only the latter is present in appreciable amounts. Schmidlin³ found that a 2% benzene solution of triphenylmethyl, upon diluting ten times, increases in color to about two and one-half times the original intensity. These experiments, however, as Schmidlin points out, are at best only qualitative, for the method is not exact enough to hope for any quantitative results. Schmidlin also attempted to estimate the change in dissociation with increase in temperature in a somewhat similar manner, by measuring in a colorimeter the increase in the color of a solution of the free radical upon heating. But it was found that the color of the triphenylmethyl solution at 80° did not remain constant but continually increased, and that upon cooling it did not return to its original intensity. So no definite results were obtainable.

It is apparent, therefore, that the information at the present time is, unfortunately, not of a sufficiently decisive nature to warrant us in drawing any conclusion as regards the various influences affecting the equilibrium between the dimolecular and the monomolecular triarylmethyl.

¹ *Ber.*, 37, 2041 (1904).

² *Ann.*, 381, 347 (1911); compare Hantzsch, *Ibid.*, 384, 135 (1911); 398, 379 (1913).

³ Schmidlin, "Das Triphenylmethyl" (Stuttgart, 1914), p. 67.

Relation between Dissociation and the Nature of the Aryl Groups.—

Although triphenylmethyl, the first and simplest representative of the triarylmethyls, was found to be largely in the dimolecular state, some of its analogs were found to exist to a large extent as monomolecular. Among the first triarylmethyls of this kind was the series containing *p*-biphenyl groups:

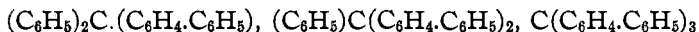

Schlenk and his co-workers¹ concluded from the measurements of the molecular weight by the cryoscopic method with benzene as a solvent, that these compounds are monomolecular to the extent of 15%, 80%, and 100%, respectively. From these results one might infer that the dissociation of the hexa-arylethane into free radicals is greatly favored by the complexity or the weight of the aryl groups, the dissociation becoming apparently more manifest also in proportion to the number of such groups. Some support in favor of this inference is given by the α -naphthylidiphenylmethyl, which was found to be monomolecular to the extent of 60%.² It appears strange, however, that one naphthyl group which is no heavier and apparently no more complex than a biphenyl group, should favor dissociation to almost the same degree as two biphenyl groups. In harmony with this marked influence of the naphthyl group is also the fact that phenyl-biphenyl- α -naphthyl-methyl is completely monomolecular. But the hypothesis that the dissociation of the hexa-arylethanes is proportional to the complexity of the aryl groups becomes wholly untenable when

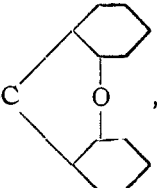
one compares triphenylmethyl with phenyl-xanthyl, C_6H_5-C ,

which, according to Schlenk and Renning,³ is monomolecular to the extent of 82%. Is the union of the two phenyl groups the paramount influence in this case? If so, why does phenyl-thioxanthyl, with sulfur in the place of the oxygen atom, dissociate, according to Schlenk and Renning's results, only to the extent of 14%? And why should a substance, constitutionally so closely related to the xanthyls as phenyl-bi-

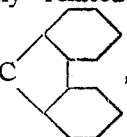
phenylene-methyl, C_6H_5-C , be completely dimolecular?⁴

¹ *Ann.*, **394**, 186 (1912); *Ber.*, **43**, 1756 (1910); *Ann.*, **372**, 4 (1909); Schmidlin and Garcia-Banus, *Ber.*, **45**, 3176 (1912).

² Schlenk and Renning, *Ann.*, **394**, 193 (1912).

³ *Ann.*, **394**, 190 (1912).

⁴ Schlenk, Herzenstein and Weickel, *Ber.*, **43**, 1754 (1910).

It is obvious that from the few facts known to us at present, it is difficult, if not wholly impossible, to formulate the relation between the complexity of the aryl groups in the hexa-arylethanes on the one hand, and the tendency of these ethanes towards dissociation into free radicals on the other.

The Problem of This Investigation.

In order to obtain some further knowledge as to the factors governing the equilibrium between the di- and the monomolecular phase of triarylmethyls, we decided to select for our study a related set of compounds. The following triarylmethyls were prepared for this purpose:

1. $(C_6H_5)_3C$ Triphenylmethyl.
2. $(C_6H_5)_2C.C_{10}H_7$ α -Naphthyldiphenylmethyl.
3. $C_6H_5.C \begin{array}{l} \diagup C_6H_4 \\ \diagdown C_6H_4 \end{array} O$ Phenyl-xanthyl.
4. $CH_3C_6H_4.C \begin{array}{l} \diagup C_6H_4 \\ \diagdown C_6H_4 \end{array} O$ *p*-Tolyl-xanthyl.
5. $ClC_6H_4.C \begin{array}{l} \diagup C_6H_4 \\ \diagdown C_6H_4 \end{array} O$ *p*-Chlorophenyl-xanthyl.
6. $C_{10}H_7.C \begin{array}{l} \diagup C_6H_4 \\ \diagdown C_6H_4 \end{array} O$ α -Naphthyl-xanthyl.
7. $C_6H_5.C \begin{array}{l} \diagup C_6H_4 \\ \diagdown C_{10}H_6 \end{array} O$ Phenyl-pheno- β -naphtho-xanthyl.

We carefully determined the molecular weight of triphenylmethyl in naphthalene, and then under exactly the same conditions we determined the molecular weight of α -naphthyldiphenylmethyl. This was to furnish the desired knowledge as to the influence of one naphthyl group in comparison with one phenyl group. Next, phenyl-xanthyl was compared with *p*-chlorophenyl-xanthyl, *p*-tolyl-xanthyl, and α -naphthyl-xanthyl. With the favorable influence of the xanthone ring towards dissociation known, we would thus be enabled to measure the comparative influence of the groups C_6H_5 , *p*- ClC_6H_4 , *p*- $CH_3C_6H_4$, and α - $C_{10}H_7$. We next compared the degree of dissociation of α -naphthyl-xanthyl with phenyl-pheno-

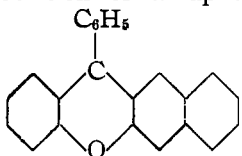
β -naphtho-xanthyl,  This should furnish us, it

was hoped, data for comparing the influence of the naphthyl group in the two different positions, in one as an independent aryl group and in the other as a component of the xanthone ring.

A determination of the molecular state, and consequently of the dissociation phenomenon, of these unsaturated compounds is the more pertinent in view of the limited number of radicals upon which such determinations have been conducted. There is no reason to doubt the general accuracy of the results published by others in this connection, but it is unfortunate that the details furnished with regard to the purification of the materials, and to the methods employed, have been so meager. Accurate as the molecular-weight determinations in themselves might have been, there is no very definite assurance that the free radicals used were actually pure, or that, if pure, they withstood the action of heat on drying, which operation was carried out in some cases at a temperature as high as 100°. In no instance, as far as we are aware, was a verification of the purity of the free radical made by determining quantitatively how much oxygen it would absorb, or how much peroxide it would yield. And yet this is a very essential and one of the safest criterions of the purity of the triarylmethyls. From the experience in this laboratory we have learned that some hexa-arylethanes lose through spontaneous isomerization the capacity of absorbing oxygen without, however, undergoing any apparent change in molecular weight. Then again, there have been found triarylmethyls, almost wholly monomolecular, which on warming to 50–60° are isomerized to a large extent and lose their capacity to form peroxide, although the molecular weight of the mixture still remains apparently the same.

Our aim has been to take every possible precaution to insure uniformity and purity of the triarylmethyls to be used. As a check, the capacity for oxygen absorption and for peroxide formation was always resorted to, using part of the very same sample which served for the determination of the molecular weight. Also, it was made certain that during the course of the determination the triarylmethyl suffered no deleterious isomerization due to the effect of the temperature (80°) of the solvent, naphthalene.

The triarylmethyls prepared under these conditions were studied from two points of view: (1) The molecular weight of every triarylmethyl was determined within a fairly wide range of concentration in order to determine the effect of concentration upon the degree of dissociation. (2) From a comparison of the degree of dissociation of various triarylmethyls, under the same conditions of solvent, concentration, and temperature, it was hoped that something would be learned regarding the influence of the various aryl groups upon the tendency of the ethane towards dissociation.

Preparation of the Free Radicals.

The triphenylmethyl was prepared for these experiments by the action of metallic mercury upon triphenylchloromethane, with the addition of

a small amount of powdered lead, which greatly facilitates the settling of the finely divided mercurous chloride, formed during the reaction. Five grams of the chloride, 5 g. of mercury, and about 0.5 g. of lead powder are placed in a small Drechsel bottle, and enough dry benzene, about 75 cc., is added to almost fill the bottle, which is provided with a well-fitting cork covered with parchment paper in such a manner that none of the paper projects beyond the neck of the flask. After several hours' shaking the reaction is complete. The mercury is now allowed to settle, the cork removed, and there is rapidly inserted the glass connection which permits the syphoning off of the liquid into the apparatus¹ B, shown in Fig. I, the bulb having been previously exhausted thoroughly. The benzene is distilled under reduced pressure, by wrapping the bulb with rubber tubing through which steam is passed, and the product recrystallized from hot acetone. The solvent is drawn off and the beautifully

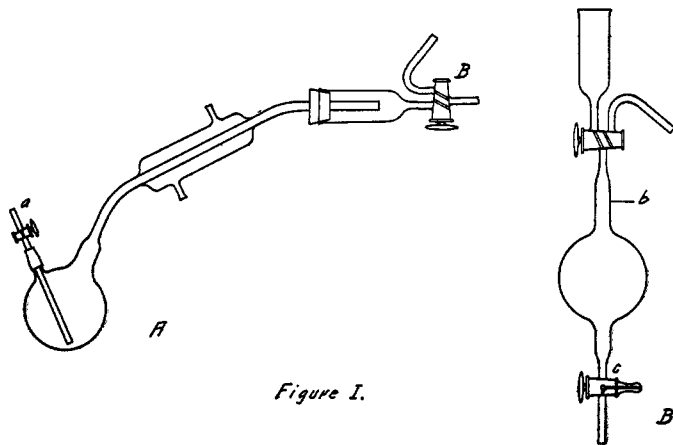

Figure I.

crystalline triphenylmethyl is washed, and thoroughly dried in vacuum in a slow stream of carbon dioxide. The material is then removed from the apparatus by breaking at *b*, quickly put in a porcelain boat which is placed into a glass tube and heated in an air bath in vacuum for one and one-half hours at a temperature of 60–65°, a slow stream of carbon dioxide being passed at the same time through the tube. By this treatment the complete removal of any solvent of crystallization is insured. In the case of α -naphthyldiphenylmethyl, the procedure was the same except that molecular silver was substituted for mercury.

For the preparation of the xanthyls, however, this method was not applicable because of their slight solubility in benzene or other solvents at room temperature, and it was necessary to modify the apparatus so as to admit of the use of warm benzene as a solvent. The neck of a 150

¹*Ber.*, 37, 2033 (1904).

cc. vacuum distillation flask was cut off and a piece of 8 mm. glass tubing about 35-40 cm. long was sealed to the flask. A small condensing jacket was attached, and the tube bent into the shape shown in A, Fig. I. About 4 g. of the chloride and 4 g. of molecular silver are placed in the flask and a snugly fitting glass tube carrying a stopcock is thrust into the side arm in such a manner as to reach almost to the bottom of the flask, a piece of rubber tubing being wired over the joint to make it air-tight. The apparatus is then set up as shown with the flask immersed in a glycerine bath, the two parts, A and B, being connected by a rubber stopper which is lightly greased. A plug of cotton and a folded filter paper are placed in the carbon tube of B. After the air is completely removed from the entire apparatus by successively evacuating through the stopcock *c* and filling with carbon dioxide through the tube *a*, about 100 cc. of benzene are drawn in through this tube. The solution is then gently boiled for about two hours, a slow stream of carbon dioxide being passed through the flask, which stirs up the liquid and also prevents bumping (a few pieces of porous plate are likewise useful for this purpose). The carbon dioxide leaves the apparatus through the stopcock *c*, passing through a mercury or benzene trap to guard against any backward diffusion of air. When the reaction is complete the bulb B is evacuated and the apparatus inclined so as to allow the solution to be transferred from the flask A into B, the liquid being filtered in this process. The solution is now concentrated and the radical allowed to crystallize from benzene. When the product was obtained in fairly large crystals, as was generally the case, the solvent was decanted and the material washed with benzene and dried in the same manner as triphenylmethyl. But in the experiments with phenyl-pheno- β -naphtho-xanthyl and occasionally with tolyl-xanthyl, the product was so finely crystalline that the solvent could not be readily decanted. Therefore a carbon tube to which a stopcock is sealed, was attached to the lower part of B by means of a rubber stopper, and connected to a vacuum pump. In the carbon tube was fitted a perforated porcelain disk upon which a filter paper cut slightly larger than the tube itself, was firmly pressed. After the air is removed from the tube by successively evacuating and filling with carbon dioxide through the stopcock, *c*, the solution carrying the crystals in suspension is filtered through the disk. The procedure of washing and drying the material which remains upon the filter is practically the same as before.

Purity of the Free Radicals.

The melting point of the free radical was found to give the best indication of its purity. A small amount of the sample is placed in one arm of a melting-point tube bent into a U shape, and the air removed by passing a stream of carbon dioxide through the tube. After fusing one end, the other is drawn into a fine capillary which is then fused. The tube is

attached to the thermometer so that the capillary projects above the surface of the sulfuric acid in the heating bath, and when a temperature about 20° below the melting point of the substance is reached, the tip of the capillary is broken. With a sufficiently fine capillary the further increase of the temperature prevents any diffusion of air into the tube.

The absorption of oxygen, which has become a standard test for the presence and the purity of a free radical, was measured in every case, using a portion of the same sample which served in determining the molecular weight. The apparatus shown in Fig. II consisted of a gas buret, provided with a water jacket and to which was attached an upright piece of large glass tubing, the connection being made at the bottom to form a U, with a stopcock at the lower bend. Liquid could be added at the open end of the tube or drawn off through the stopcock at the bottom, thereby offering a convenient method of accurately leveling the surfaces of the liquid in the buret and in the tube. The buret was attached by means of a thick-walled rubber tubing to a 175 cc. Drechsel bottle, of which the side arm had been sealed and the tube projecting into the flask cut off as short as possible. Although the bottle was provided with a well-ground glass joint, nevertheless it was always sealed with paraffin as an added precaution. The use of benzene as the solvent was found to give considerable trouble due to its high vapor tension which caused appreciable changes in volume with comparatively small changes in temperature. Consequently, bromobenzene was substituted which proved to be very satisfactory as it is a good solvent and has a vapor tension so low as to be practically negligible at room temperature. Bromobenzene was also used instead of mercury¹ in the buret and leveling tube as it permitted more accurate leveling.

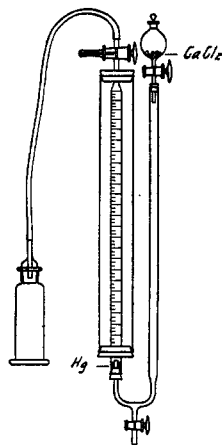

Figure II.

From 0.5 to 1.0 g. of the free radical, in the form of pellets, is put in a small test tube which is then filled with bromobenzene and quickly sealed. The tube is placed in the absorption bottle, covered with about 25 cc. of bromobenzene, and the bottle sealed with paraffin and submerged in a large pail of water which is kept at the desired temperature. The apparatus is now filled with dry oxygen and, after the temperature has become constant, the bottle is shaken to break the tube. The absorption is measured by means of the buret. During the course of the experiment, the temperature of the bottle and the buret was kept constant, while corrections were applied to allow for changes in barometric pressure.

¹ *Ber.*, 37, 3539 (1914).

The Determination of the Molecular Weight.

Apparatus.—Experiments were first made to determine the molecular weights by the ebullioscopic method using benzene and chloroform as solvents. This method proved to be unsatisfactory as it did not lend itself to a sufficient degree of accuracy, partly because of the relatively small rise in boiling point in the case of compounds having high molecular weights and partly because of the decided fluctuations in the boiling point due to external conditions, such as changes in the pressure. It was therefore necessary to revert to the cryoscopic method which gave admirable results. The apparatus was of the type devised by Beckmann in which a two-ring stirrer is used, the upper ring being of wrought iron covered with platinum. This is attracted by an electromagnet attached on the outside of the freezing vessel, and rises and falls due to the alternate making and breaking of the current, effected by a metronome. The freezing vessel was of the usual type, the Beckmann thermometer being held in place by a rubber stopper which was found to give the necessary firmness. A piece of small glass tubing was passed through this stopper to allow the introduction of an inert gas into the vessel. The side arm was provided with a rubber stopper which carried a glass tube, to serve as an outlet for the inert gas, and also a small trigger. This trigger consisted of a piece of heavy nickel wire one end of which had been flattened and bent at a right angle to form a hoe. It served the purpose of holding in place the material which was added in the form of pellets, and also afforded a means of adding these pellets one at a time during the course of the experiment. The freezing vessel, provided as usual with an air jacket, was immersed in a large porcelain beaker filled with water which was kept at the desired temperature, about 75° , by heating with a small flame.

Hydrogen was selected as the most convenient of the inert gases which could be used. The gas was generated in a Kipp by the action of dilute sulfuric acid on granulated zinc, washed with an acid solution of potassium permanganate and thoroughly dried by passing through concentrated sulfuric acid and through a calcium chloride tower.

Most of the free radicals which were studied are but slightly soluble in the solvents ordinarily used for molecular-weight determinations such as benzene, nitrobenzene, *p*-bromotoluene, etc., at the temperature of their freezing points, and consequently these were not applicable for our purpose. Naphthalene, however, was found to be an excellent solvent at the temperature of its freezing point, 80° , and was therefore selected. It was always carefully distilled before using.

For obvious reasons it was thought advisable to determine the molecular depression constant for this particular apparatus and under exactly the same conditions that were to prevail in all the following experiments.

For substances to serve in obtaining this constant, triphenylmethane and triphenylcarbinol seemed most desirable as they were of approximately the same molecular weight as the radicals to be studied, and also allied to them in regard to their chemical nature. The samples of triphenylmethane and triphenylcarbinol were purified by repeated crystallizations from benzene and carefully dried. From a number of very concordant determinations the molecular depression constant for naphthalene was found to be 70.27 or approximately 70.3, which factor was used in subsequent experiments.

A correction was made to the weight of the solvent, since the amount which solidifies due to the supercooling decreases the actual quantity of material functioning as a solvent and thereby increases the concentration. Using 0.4824 as the specific heat and 35.679 as the heat of fusion of naphthalene, we find that for 18 g. of solvent about 0.085 g. solidifies due to the supercooling, which is fairly uniform and averages 0.35° . Moreover, approximately 0.05 to 0.10 g. of naphthalene sublimates in the freezing vessel during the course of the experiment. Therefore, in order to correct for the increase in concentration due to these two factors, an empirical correction of 0.15 g. was applied, this amount being subtracted from the original weight of the solvent.

Manipulation.—After the free radical has been thoroughly dried, it is removed from the air bath and quickly made into pellets by means of a small tablet press. Several of these pellets of convenient size are selected, carefully weighed one at a time, and laid in a row in the side arm of the freezing vessel, being held in place by the trigger. The air is removed from the apparatus by successively evacuating through the outlet tube leading from the side arm, and filling with hydrogen which enters through the tube in the stopper carrying the thermometer. During the course of the experiment, a very slow stream of hydrogen is passed through the freezing vessel, the outlet tube dipping into a small flask containing a non-volatile liquid such as nitrobenzene which acts as a trap and prevents any diffusion of air into the apparatus. When the freezing point of the pure solvent has been accurately checked, the pellets are added one at a time by means of the trigger, the depression of the freezing point being determined for each addition. It will be noticed that the apparatus remains sealed to the air throughout the entire operation. As a rule, four additions were made, which provided concentrations ranging from 1 to 5%. The results are plotted in the form of curves, using the concentrations as abscissas and molecular weights as ordinates.

Except in the case of *p*-chlorophenyl-xanthy, successive determinations showed that the freezing point of the solution of any definite concentration remained perfectly constant. This precluded the possibility that the hexa-arylethane was being reduced to triarylmethane by the hydrogen

in virtue of the catalytic effect of the platinum stirrer, for if such a reduction did occur it would necessarily be gradual and would be accompanied by a marked depression of the freezing point. Moreover, no hydrogen was absorbed during the course of the experiment. The fact that the freezing point remained constant also proved that no polymerization was taking place under the influence of the temperature, as this would be accompanied by a steady rise of the freezing point. Indeed, if the solution, poured into a shallow dish at the end of the experiment, is allowed to stand in the hood for several months, most of the naphthalene sublimes off, and by washing with a little petroleum ether between 75 to 80% of the peroxide can be recovered, offering in this way conclusive evidence that the free radical undergoes no change during the molecular-weight determination. It should be remarked that each experiment represents an individual preparation and that in no case were two determinations of the molecular weight made upon the same sample. Moreover the sample was never more than one day old, the free radical being prepared in the afternoon, allowed to crystallize overnight, isolated the following morning and the molecular weight taken the same afternoon.

1. Triphenylmethyl.

The triphenylmethyl, prepared by the action of mercury upon triphenylchloromethane, is obtained in good yields by concentrating the benzene solution and recrystallizing from acetone. The crystals which are quite large, have a pale yellow color when dried, and melt at 145–147°.¹

Absorption of Oxygen.—0.9057 g. of triphenylmethyl absorbed 44.1 cc. of oxygen at 745 mm. pressure and at a temperature of 23° which amounts to 95.5% of the theoretical absorption.

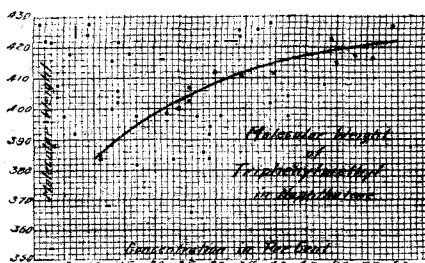

Curve I.

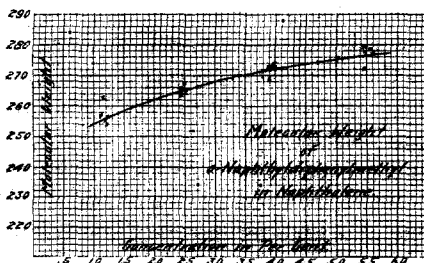

Curve II.

2. α -Naphthyl-diphenylmethyl.

The α -naphthyl-diphenylmethyl was prepared in benzene by the action of molecular silver upon α -naphthyl-diphenylchloromethane, the solution having a deep reddish brown color. Upon concentrating and adding acetone, the free radical is obtained in small crystals of a pale yellow color

¹ Ber., 37, 2037 (1904).

which upon heating turn brown at about 130° , and melt at $135-137^{\circ}$, although the melting point is not sharp. This free radical has been described by Schlenk and Renning¹ as a grayish black powder when dry. They determined its molecular weight in benzene by the cryoscopic method obtaining values of 372 and 363 in approximately a 2.5% solution.

The α -naphthylidiphenylmethylperoxide which is formed when a solution of the free radical is exposed to air, is practically insoluble in petroleum ether and benzene but is slightly soluble in hot carbon disulfide. It crystallizes from the latter solvent in very fine, colorless crystals which melt at $172-173^{\circ}$ with decomposition.

Absorption of Oxygen.—0.6550 g. of α -naphthylidiphenylmethyl absorbed 26.0 cc. of oxygen at 743 mm. pressure and at a temperature of 30° , which amounts to 91.5% of the theoretical absorption.

3. Phenyl-xanthy.

The phenyl-xanthenol for these experiments was prepared from xanthone and phenylmagnesiumbromide. The carbinol is changed to the corresponding chloride-hydrochloride by dissolving in benzene, adding sufficient acetyl chloride to form the chloride, and then passing dry hydrochloric acid gas through the solution. The phenyl-xanthyenylchloride-hydrochloride is carefully dried in the absence of moisture and suspended in benzene, which is boiled until all the hydrochloric acid is expelled. Upon concentrating or upon the addition of petroleum ether to the solution, the phenyl-xanthyenylchloride is obtained in large, colorless crystals which must also be carefully protected from moisture.²

Five grams of phenyl-xanthyenylchloride and 5 g. of molecular silver in benzene, gave a deep red solution which upon concentrating yielded about 2 g. of phenyl-xanthy in well-defined crystals. (It might be remarked that the yield was always sacrificed in favor of the purity of the sample.) The crystals have a pure yellow color and melt at $166-168^{\circ}$. This free radical has been described by Schlenk and Renning³ as brown crystals which give a yellow powder on drying. They determined its molecular weight in benzene by the ebullioscopic method, obtaining values of 279 and 287 in approximately a 1.5% solution.

Absorption of Oxygen.—0.8510 g. of phenyl-xanthy absorbed 38.5 cc. of oxygen at 733 mm. pressure and at a temperature of 23° , which amounts to 92.3% of the theoretical absorption.

4. *p*-Tolyl-xanthy.

The *p*-tolyl-xanthenol which was prepared from xanthone and *p*-tolylmagnesiumiodide,⁴ was changed into the corresponding chloride-hydrochloride and then into the chloride as in the case of the phenyl derivative.

¹ *Ann.*, 394, 192 (1912).

² Gomberg and Cone, *Ibid.*, 370, 155 (1909).

³ *Ann.*, 394, 190 (1912).

⁴ *Ibid.*, 370, 164 (1909).

The tolyl-xanthyl is obtained in about the same yield as the phenyl-xanthyl; like the latter it is yellow in color, while its benzene solution is also deep red. The crystals melt at 156–158°.

Absorption of Oxygen.—0.6270 g. of *p*-tolyl-xanthyl absorbed 27.6 cc. of oxygen at 744 mm. pressure and at a temperature of 23°, which amounts to 96.2% of the theoretical absorption.

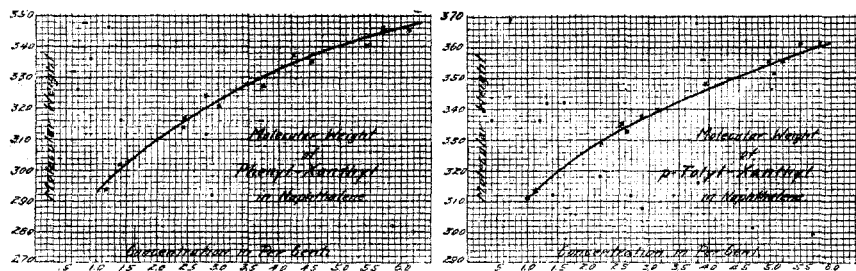

Curve III.

Curve IV.

5. *p*-Chlorophenyl-xanthyl.

The *p*-chlorophenyl-xanthenol which was prepared from xanthone and *p*-chlorophenylmagnesiumiodide, was changed into the chloride-hydrochloride and then into the chloride as in the previous cases.¹ The free radical is obtained from its benzene solution, which has a deep red color, in well-defined, light yellow crystals melting at 149–151°. Here again, there is no marked difference in color between the *p*-chlorophenyl-xanthyl and the phenyl- or tolyl-xanthyls either as solids or when in solution. The yield, however, was somewhat smaller, about 1 g. of the free radical being obtained from 5 g. of the chloride.

Absorption of Oxygen.—0.6320 g. of *p*-chlorophenyl-xanthyl absorbed 23.6 cc. of oxygen at 751 mm. pressure and at a temperature of 23°, which amounts to 88.7% of the theoretical absorption.

In determining the molecular weight it was found that the freezing point of the solution, after an addition had been made, did not remain constant, but rose with each successive determination of the freezing point, the rise in fifteen minutes amounting to about 1.5% of the total depression of the freezing point. This rise in the freezing point was attributed to a gradual polymerization of the monomolecular free radical or to isomerization of the hexa-arylethane under the influence of the relatively high temperature to a stable compound which is no longer capable of giving rise to the free radical.² That this was indeed quite likely to be the case, was shown by measuring the amount of oxygen absorbed by two portions of a sample of *p*-chlorophenyl-xanthyl, one of which was heated while the other was not. A weighed portion of the sample was put into a small

¹ *Ann.*, 370, 174 (1909).

² *Ber.*, 36, 378 (1903); Tschitschibabin, *Ibid.*, 41, 2421 (1908); Gomberg and Jickling, *THIS JOURNAL*, 37, 2587 (1915).

test tube, and enough bromobenzene added to almost fill the tube which was then heated at a temperature of 80–85° for two hours in an atmosphere of nitrogen. The tube was allowed to cool to room temperature and quickly sealed. The other portion of the sample was treated in a similar manner except that it was not subjected to heating.

Absorption of Oxygen by the Unheated Sample.—0.5908 g. of *p*-chlorophenyl-xanthyI absorbed 21.8 cc. of oxygen at 741 mm. pressure and at a temperature of 23°, which amounts to 86.5% of the theoretical absorption.

Absorption of Oxygen by the Heated Sample.—0.5125 g. of *p*-chlorophenyl-xanthyI absorbed 4.7 cc. of oxygen at 741 mm. pressure and at a temperature of 23°, which amounts to 21.5% of the theoretical absorption.

It is seen, therefore, that by subjecting the solution of the free radical for two hours to a temperature of 80–85°, which is approximately the temperature maintained during the determination of the molecular weight, the compound suffered a change—probably has polymerized or isomerized—to such an extent as to decrease the absorption from 86.5 to 21.5% of the theoretical amount of oxygen. This tendency towards polymerization or isomerization may explain the relatively small yield of *p*-chlorophenyl-xanthyI when prepared in a warm benzene solution. However, the compound which is formed is exceedingly soluble in benzene and is completely separated from the crystalline free radical by washing with this solvent.

Chlorine Estimation in *p*-Chlorophenyl-xanthyI.—For this determination a sample of the free radical was burned with sodium peroxide. 0.4106 g. required 14.20 cc. of 0.1 *N* silver nitrate solution.

Calc. for $C_{19}H_{12}OCl$: Cl, 12.16%. Found: 12.26%.

Because of the possible polymerization of this free radical, only one addition was made in each experiment and the first determination of the depression of the freezing point, which was taken as soon as the material was completely in solution, was regarded as being correct. For similar reasons, the molecular weights are estimated to be about 1% too high in virtue of the polymerization in the brief interval between the addition of the material and the first determination of the depression of the freezing point.

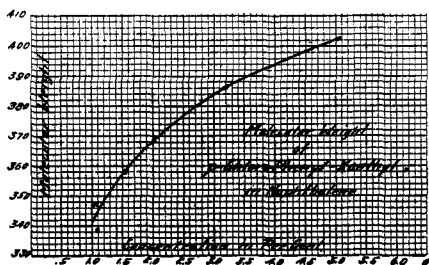

Curve V.

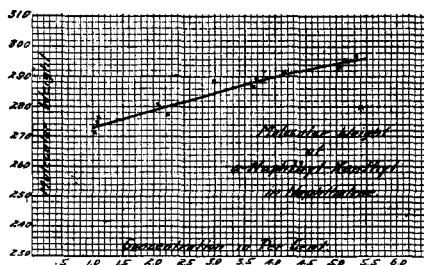

Curve VI.

6. α -Naphthyl-xanthyl.

The α -naphthyl-xanthenol was prepared, in good yields, from xanthone and α -naphthylmagnesiumbromide. It crystallizes from benzene or from a mixture of benzene and petroleum ether in large, colorless plates containing benzene of crystallization. The pure carbinol melts at $198-199^{\circ}$.

The α -naphthyl-xanthenylchloride-hydrochloride is prepared by passing dry hydrochloric acid through a solution of the carbinol to which a few cc. of acetyl chloride have been added. It is obtained as a voluminous mass of very fine, orange-red crystals, which melt at $190-200^{\circ}$, depending upon the rate of heating.

The α -naphthyl-xanthenylchloride is prepared by boiling the hydrochloride in benzene to expel the hydrochloric acid; it crystallizes upon concentrating, or upon the addition of petroleum ether to the solution, in large, colorless prisms. On heating, these begin to sinter at 165° and melt at $172-173^{\circ}$.

Chlorine Estimation in α -Naphthyl-xanthenylchloride.— 0.4015 g. required 11.8 cc. of 0.1 *N* silver nitrate solution.

Calc. for $C_{22}H_{16}OCl$: Cl, 10.35% . Found: 10.19% .

The α -naphthyl-xanthenylperoxide, which is formed when a solution of the free radical is exposed to the air, is practically insoluble in petroleum ether or in cold benzene, and but slightly soluble in hot benzene. It is colorless when pure and melts at $228-230^{\circ}$ with decomposition.

The α -naphthyl-xanthyl is obtained from its benzene solution in fine, yellow crystals, which show no noticeable difference in color from the phenyl- and tolyl-xanthyls. The solution in benzene or in naphthalene, however, is a very deep red, being darker than the solutions of the two radicals last mentioned. The melting point of the pure compound is $175-177^{\circ}$.

Absorption of Oxygen.— 0.9883 g. of α -naphthyl-xanthyl absorbed in one hour 38.1 cc. of oxygen at 735 mm. pressure and at a temperature of 23° , which amounts to 94.3% of the theoretical absorption. There was a further gradual absorption which amounted to 1.5 cc. in the course of six hours.

7. Phenyl-pheno- β -naphtho-xanthyl.

The phenyl-pheno- β -naphtho-xanthenol was prepared, in good yields, from pheno- β -naphtho-xanthone¹ and phenylmagnesiumbromide. The carbinol crystallizes from benzene or from a mixture of benzene and petroleum ether, in small, colorless, brilliant crystals which melt at 171° .

For the preparation of the phenyl-pheno- β -naphtho-xanthenyl-chloride-hydrochloride, the carbinol is dissolved in benzene, a few cc. of acetyl chloride added, and a stream of dry hydrochloric acid passed through the solution, upon which the hydrochloride crystallizes in small, flat, glistening prisms of an orange-red color. The melting point ranges from $145-$

¹ Ullmann, *Ber.*, **38**, 2117 (1905).

155°, depending on the rate of heating, as the compound loses hydrochloric acid.

The phenyl-pheno- β -naphtho-xanthenylchloride is obtained by suspending the hydrochloride in benzene and boiling until all the hydrochloric acid is expelled. Upon concentrating the solution, or upon the addition of petroleum ether, the chloride crystallizes in large, colorless prisms which melt at 137°.

The phenyl-pheno- β -naphtho-xanthenylperoxide is formed when a solution of the free radical is exposed to the air; it is practically insoluble in petroleum ether, slightly soluble in cold benzene but quite soluble in hot benzene. It crystallizes from benzene in fine, colorless crystals which on heating begin to darken at 225° and melt at 229° with decomposition.

The phenyl-pheno- β -naphtho-xanthyI is obtained from its benzene solution in minute, yellow crystals, somewhat lighter in color than the other free radicals. It is practically insoluble in cold benzene and is soluble in naphthalene at the temperature of the freezing point of the latter only to the extent of about two and one-half per cent. The solution of the free radical in hot benzene or in naphthalene has a brilliant, emerald-green color. The pure compound melts at 212-214°.

Absorption of Oxygen.—When pure oxygen was used, it was found that the free radical absorbed about 40% more than the theoretical amount. 0.5238 g. of phenyl-

pheno- β -naphtho-xanthyI absorbed in one-half hour 31.0 cc. of oxygen at 727 mm. pressure and at a temperature of 23°, which amounts to 143% of the theoretical absorption. Although the most of the oxygen was absorbed as fast as the free radical entered into solution, there was also a subsequent gradual absorption probably due to some decomposition. This amounted to 2-3 cc. in the course of four hours. However, when air instead of oxygen was used, the absorption was nearly theoretical. 0.3158 g. of the phenyl-

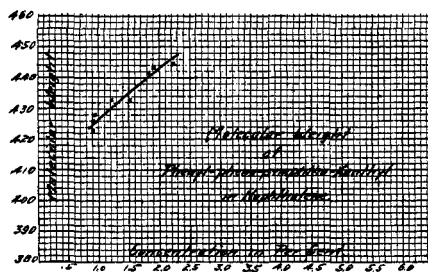

Curve VII.

pheno- β -naphtho-xanthyI absorbed in one-half hour 12.1 cc. of oxygen at 741 mm. pressure and at a temperature of 23°, which amounts to 94.5% of the theoretical absorption. In this case there was but little further absorption.

MOLECULAR WEIGHT OF THE TRIARYLMETHYLS IN NAPHTHALENE.

| Substance and molecular weight calculated for R_3C . | Naphthalene (g.) (corrected). | Triarylmethyl (g.). | Concentration (%). | Depression of freezing point. | Molecular weight. |
|--|-------------------------------|---------------------|--------------------|-------------------------------|-------------------|
| I (243.1) | 16.24 | 0.4905 | 3.02 | 0.515 | 412.3 |
| | | 0.9560 | 5.89 | 0.969 | 427.1 |
| | 17.87 | 0.4604 | 2.58 | 0.445 | 407.0 |
| | | 0.8751 | 4.90 | 0.814 | 422.9 |
| | | 0.4605 | 2.57 | 0.448 | 402.6 |
| | 17.95 | 0.8978 | 5.00 | 0.848 | 414.7 |
| | | 0.1962 | 1.11 | 0.203 | 383.9 |

MOLECULAR WEIGHT OF THE TRIARYLMETHYLS IN NAPHTHALENE (*continued*).

| Substance and molecular weight calculated for R ₃ C. | Naphtha- lene (g.) (corrected). | Triaryl- methyl (g.). | Concentra- tion (%). | Depression of freez- ing point. | Molecular weight. |
|---|---------------------------------------|--------------------------|-------------------------|---------------------------------------|----------------------|
| | | 0.3897 | 2.20 | 0.388 | 398.9 |
| | | 0.6109 | 3.45 | 0.591 | 410.6 |
| | | 0.9418 | 5.32 | 0.896 | 417.5 |
| | 17.81 | 0.1913 | 1.07 | 0.196 | 385.3 |
| | | 0.4244 | 2.38 | 0.419 | 399.8 |
| | | 0.7046 | 3.96 | 0.676 | 411.4 |
| | | 0.9991 | 5.61 | 0.947 | 416.4 |
| 2 | 17.67 | 0.2146 | 1.21 | 0.336 | 254.1 |
| (293.1) | | 0.4343 | 2.46 | 0.655 | 263.8 |
| | | 0.6908 | 3.91 | 1.020 | 269.4 |
| | | 0.9666 | 5.47 | 1.413 | 272.2 |
| | 17.73 | 0.2175 | 1.23 | 0.336 | 256.7 |
| | | 0.4445 | 2.51 | 0.667 | 264.2 |
| | | 0.7125 | 4.02 | 1.035 | 273.0 |
| | | 0.9911 | 5.59 | 1.419 | 276.9 |
| | 17.80 | 0.2065 | 1.16 | 0.310 | 263.1 |
| | | 0.4430 | 2.49 | 0.654 | 267.5 |
| | | 0.7038 | 3.95 | 1.019 | 272.8 |
| | | 0.9766 | 5.49 | 1.388 | 277.9 |
| | 17.91 | 0.2136 | 1.19 | 0.329 | 254.8 |
| | | 0.4402 | 2.46 | 0.649 | 266.2 |
| | | 0.7073 | 3.95 | 1.016 | 273.3 |
| | | 0.9942 | 5.55 | 1.401 | 278.5 |
| | 17.81 | 0.1976 | 1.11 | 0.304 | 256.6 |
| | | 0.4387 | 2.46 | 0.655 | 264.4 |
| | | 0.6982 | 3.92 | 1.011 | 272.6 |
| | | 0.9740 | 5.47 | 1.380 | 278.6 |
| 3 | 18.15 | 0.4435 | 2.44 | 0.542 | 316.9 |
| (257.1) | | 0.8736 | 4.81 | 0.998 | 339.0 |
| | 17.99 | 0.2457 | 1.37 | 0.318 | 301.9 |
| | | 0.5037 | 2.80 | 0.607 | 324.3 |
| | | 0.7649 | 4.25 | 0.886 | 337.4 |
| | | 1.0299 | 5.72 | 1.163 | 346.1 |
| | 18.04 | 0.2687 | 1.49 | 0.346 | 302.6 |
| | | 0.5419 | 3.00 | 0.658 | 320.9 |
| | | 0.8214 | 4.55 | 0.954 | 335.5 |
| | | 1.1076 | 6.14 | 1.249 | 345.6 |
| | 17.71 | 0.2020 | 1.14 | 0.273 | 293.7 |
| | | 0.4302 | 2.43 | 0.544 | 313.9 |
| | | 0.6656 | 3.76 | 0.806 | 327.8 |
| | | 0.9636 | 5.44 | 1.124 | 340.3 |
| 4 | 15.87 | 0.4577 | 2.88 | 0.600 | 337.9 |
| (271.1) | | 0.9240 | 5.82 | 1.134 | 360.9 |
| | 17.79 | 0.4688 | 2.64 | 0.556 | 333.2 |
| | | 0.9024 | 5.07 | 1.014 | 351.7 |
| | 18.15 | 0.4638 | 2.56 | 0.536 | 335.2 |
| | | 0.9028 | 4.97 | 0.983 | 355.7 |

MOLECULAR WEIGHT OF THE TRIARYLMETHYLS IN NAPHTHALENE (*concluded*).

| Substance and molecular weight calculated for R ₃ C. | Naphthalene (g.) (corrected). | Triaryl-methyl (g.). | Concentration (%). | Depression of freezing point. | Molecular weight. |
|---|-------------------------------|----------------------|--------------------|-------------------------------|-------------------|
| | 17.34 | 0.1935 | 1.12 | 0.250 | 313.8 |
| | | 0.5460 | 3.15 | 0.651 | 340.0 |
| | | 0.9028 | 5.21 | 1.029 | 355.7 |
| | 17.64 | 0.1803 | 1.02 | 0.231 | 311.1 |
| | | 0.3923 | 2.22 | 0.475 | 329.1 |
| | | 0.6975 | 3.95 | 0.798 | 348.3 |
| 5 (291.6) | 17.09 | 0.1790 | 1.05 | 0.212 | 347.3 |
| | | 0.1922 | 1.09 | 0.226 | 338.7 |
| | | 0.2647 | 1.55 | 0.304 | 358.0 |
| | 16.60 | 0.3332 | 2.01 | 0.383 | 368.4 |
| | | 0.5368 | 3.20 | 0.583 | 386.2 |
| | | 0.8577 | 5.06 | 0.883 | 402.6 |
| 6 (307.1) | 17.62 | 0.1901 | 1.08 | 0.276 | 274.8 |
| | | 0.3660 | 2.08 | 0.520 | 280.8 |
| | | 0.5242 | 2.98 | 0.725 | 288.5 |
| | 17.54 | 0.7295 | 4.14 | 0.997 | 291.9 |
| | | 0.9395 | 5.33 | 1.261 | 297.3 |
| | | 0.1931 | 1.10 | 0.280 | 276.4 |
| | 17.64 | 0.4204 | 2.40 | 0.600 | 280.8 |
| | | 0.6460 | 3.68 | 0.896 | 289.0 |
| | | 0.8999 | 5.13 | 1.219 | 295.9 |
| | | 0.1825 | 1.03 | 0.268 | 271.4 |
| | | 0.3975 | 2.25 | 0.571 | 277.4 |
| | | 0.6395 | 3.63 | 0.889 | 286.7 |
| 7 (307.1) | 19.76 | 0.8901 | 5.05 | 1.209 | 293.4 |
| | | 0.2424 | 1.23 | 0.199 | 433.4 |
| | | 0.1645 | 0.95 | 0.155 | 428.5 |
| | 17.41 | 0.3341 | 1.92 | 0.304 | 443.8 |
| | | 0.1608 | 0.92 | 0.151 | 426.1 |
| | | 0.3213 | 1.83 | 0.291 | 441.8 |
| 17.62 | 0.1601 | 0.91 | 0.151 | 423.0 | |
| | 0.2703 | 1.53 | 0.249 | 433.1 | |
| | 0.3955 | 2.25 | 0.355 | 444.5 | |

Conclusion and Summary.

In Diagram VIII are represented the curves expressing the dissociation tendency of the hexa-arylethanes (excepting two) described in this paper. The curves are plotted with the percentage of concentration as abscissas and the dissociation values, in percentages, as ordinates. The values expressing dissociation were obtained according

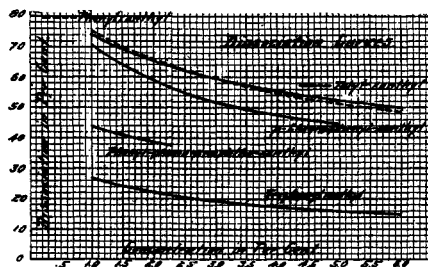

Curve VIII.

to the formula $x = (M_i - M_o)/M_o$, where x equals the degree of dissociation, M_i represents the theoretical molecular weight of the hexa-arylethane and M_o the molecular weight actually found.

The two triarylmethyls omitted from this diagram are α -naphthyl-diphenylmethyl and α -naphthyl-xanthyl. These two free radicals are under the conditions of the experiment wholly monomolecular. In fact, the actual figures obtained indicate, if anything, a molecular weight somewhat less than for the triarylmethyl itself; in other words, the dissociation of the hexa-arylethane must be more than 100%, which would be meaningless on our diagram.

1. In all instances, even in the two omitted from the diagram, a steady and gradual increase of the molecular weight is noticeable as one proceeds from a 1% concentration of the radical to that of 6%. The generality of these results, and their uniformity, leave no room for doubt that we are dealing here with a phenomenon of molecular dissociation, wherein the products of dissociation are in equilibrium with the dissociating substance. An equilibrium of this nature might be expected to shift in favor of dissociation with dilution, as is actually the case with these compounds.

2. When in triphenylmethyl two phenyl groups become joined through an oxygen atom, and thus give rise to a xanthone ring, the tendency of the new compound, phenyl-xanthyl, towards dissociation increases to a marked extent, approximately threefold. In view of this it would be desirable to repeat the experiments described by Schlenk and Renning, who report that phenyl-thio-xanthyl is monomolecular to the extent of only 14%.

3. A phenyl and a *p*-tolyl group are apparently equivalent in their influence for dissociation when linked to a xanthone ring; a *p*-chlorophenyl group is of somewhat lesser influence, as can be seen on comparing the dissociation curves of the three corresponding aryl-xanthyls. This equality of influence of a *p*-tolyl and a phenyl group would not necessarily have been anticipated. Tolyldiphenylmethyl differs very much from triphenylmethyl, and tri-*p*-tolylmethyl¹ is so unstable that it is apparently impossible to isolate it, owing to the tendency to isomerize or polymerize.

4. An α -naphthyl group when replacing a phenyl group in triphenylmethyl exerts upon the dissociation equilibrium of the compound a very decided influence in favor of the monomolecular phase, α -naphthyl-diphenylmethyl appearing as wholly dissociated. This favorable influence of the naphthyl group is still retained when the group is linked to a xanthone ring, the resulting compound being also dissociated to the extent of 100%. And yet, when the naphthyl group enters as a component in the formation of the xanthone ring itself, it depresses very decidedly the dissociation tendency of the compound, as is evident on comparing the two isomers,

¹ *Ber.*, 37, 1628 (1904).

α -naphthyl-xanthyl and phenyl-pheno- β -naphtho-xanthyl. This, indeed, is very strange, the highly favorable influence of the xanthone ring is almost wholly offset by the naphthyl group in the ring, which group is otherwise even more favorable in its dissociation influence than the xanthone ring itself. More facts are needed before we can hope to unravel this confusing interplay of various influences.

5. It has been found that the triarylmethyls are, in the solid state, almost wholly devoid of color, being, like triphenylmethyl itself, only pale yellow, but their solutions differ very much, being yellow, orange, brown, red, or green, according to the individual compound. It may be said that in the solid state the radicals are really hexa-arylethanes and therefore colorless, and that only on their going into solution does dissociation occur, and consequently is color produced. On the other hand, some of these very same radicals are monomolecular to the extent of 50 to 100%, not only in molten naphthalene but also in benzene at its freezing temperature. The inference therefrom is not entirely excluded that even in the solid phase these highly dissociable radicals must still be monomolecular to a considerable extent. If so, how can one account for their being colorless when solid?¹ Evidently it becomes difficult to account for color production in these compounds by the dissociation phenomenon alone. But by the aid of the tautomeric hypothesis the difficulties become explicable. Not dissociation alone into triarylmethyl, but, in addition, the consequent tautomerization of this into its quinonoid modification,

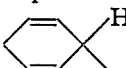
$R_2C =$ , constitute a satisfactory explanation of the color

phenomenon. It is indeed a fact that tautomerization commonly occurs only when the compound capable of tautomerization is in the liquid phase, or in solution. And that is just the case with the free radicals under consideration.

6. The two radicals, α -naphthyl-diphenylmethyl and α -naphthyl-xanthyl, were found to give a molecular weight *less* than that calculated for the monomolecular phase. Schlenk and Renning's results² show that α -naphthyl-biphenyl-phenylmethyl exhibits the same unusual behavior. We have every reason to believe that our results are not due to experimental errors, and we took pains to verify them repeatedly. We can only hazard a tentative explanation with respect to this characteristic of the radicals containing a naphthyl group. It may not be impossible that under the influence of the heavy naphthyl group, the monomolecu-

¹ Schlenk has described tribiphenylmethyl, 100% dissociated, as a dark green powder. Whether this difference in color from our completely dissociable radicals is real or only apparent we cannot at present say.

² *Ann.*, 394, 195 (1912).

lar radical suffers to a limited extent a still further dissociation, in some such manner as this:

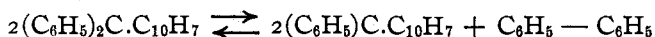

A small amount of a radical with a divalent carbon atom may thus be formed, and some biphenyl. Two molecules would then give rise to three and the freezing point would be lowered. We venture upon this explanation in a purely tentative way, and expect to subject other naphthyl derivatives to a careful study in this respect.

ANN ARBOR, MICH.

[CONTRIBUTION FROM THE CHEMICAL LABORATORY OF THE UNIVERSITY OF MICHIGAN.]

TRIPHENYLMETHYL. XXVIII. TAUTOMERISM OF TRIARYL-CARBINOLS.

BY M. GOMBERG AND L. C. JOHNSON.

Received June 13, 1917.

In a previous publication from this laboratory it was demonstrated¹ that in the triphenylmethane series the two tautomeric modifications, benzenoid and quinonoid, are actually separable from, and convertible into, each other. The first example of such separation was realized on *p*-hydroxytriphenylcarbinol,

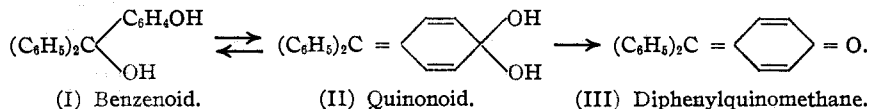

It was shown that the colored tautomer, on heating, loses water very much faster than the colorless, going over gradually into diphenylquinomethane.

Later² a convenient method was worked out for preparing readily in any desired amount the above carbinol. The method consists in the condensation of benzophenone chloride with phenol at room temperature and in absence of all catalyzers. That this ready condensation of benzophenone with phenol should have been overlooked until now is the more surprising as the equally ready condensation of phenol with benzotrichloride has been the source of innumerable investigations since the time of its discovery by Doebner in 1878.³ The condensation of benzophenone chloride with phenol takes place, as has been shown, in three stages, and all the intermediate products have been isolated:

- (1) Diphenoxydiphenylmethane, $(\text{C}_6\text{H}_5)_2\text{C}(\text{OC}_6\text{H}_5)_2$.
- (2) *p*-Hydroxytriphenylcarbinol, $(\text{C}_6\text{H}_5)_2\text{C}(\text{OH})\text{C}_6\text{H}_4\text{OH}$.
- (3) Di-*p*-hydroxytetraphenylmethane, $(\text{C}_6\text{H}_5)_2\text{C}(\text{C}_6\text{H}_4\text{OH})_2$.

¹ THIS JOURNAL, 35, 1035 (1913).

² *Ibid.*, 37, 2575 (1915).

³ *Ber.*, 12, 1462 (1879).